



Steel Reinforcement
Institute of Australia

Control of Random Cracking in Concrete Residential Pavements

Eric Lume, National Engineer, SRIA

Mark Turner, Chairman, BD-098 Pavements

What is Random Cracking?

- ➔ A crack which does not occur at a planned location
- ➔ Term from ACI Standards
- ➔ Definition added to AS 3727.1 Pavements Part 1 Residential
- ➔ Random cracking is major source of complaints
- ➔ Assessment of cracking is largely subjective
- ➔ Complicated by serviceability or aesthetics limits

Note: Cracking at planned location has no width limit



What do Residential Pavements cover?

- ➔ Footpaths – pedestrian only, 75 mm thick
- ➔ Driveways for light vehicles
 - Gross vehicle mass less than 3 t, 100 mm thick
- ➔ Driveways for commercial vehicles
 - Infrequent use by light commercial vehicles up to 10 t
 - 150 mm thick



Random Crack Width Limit

- ➔ Acceptable crack width limit set at 1 mm
- ➔ Reduced from previous 1.5 mm limit (1993) to be consistent with AS 2870 Residential slabs and footings (2011)
- ➔ Crack width limit only for a period of 1 year after construction
- ➔ Cracking can be caused by many long-term factors such as tree roots, poor drainage, moisture changes
- ➔ Limit intended to indicate possible serviceability problem



Acceptability of Cracking

- Serviceability crack widths generally regarded as aesthetically unacceptable
- Complaints relate to cracks much narrower than 1.0 mm
- Decorative pavements of particular concern
- Little information in Australia on what should be considered an aesthetically acceptable crack width

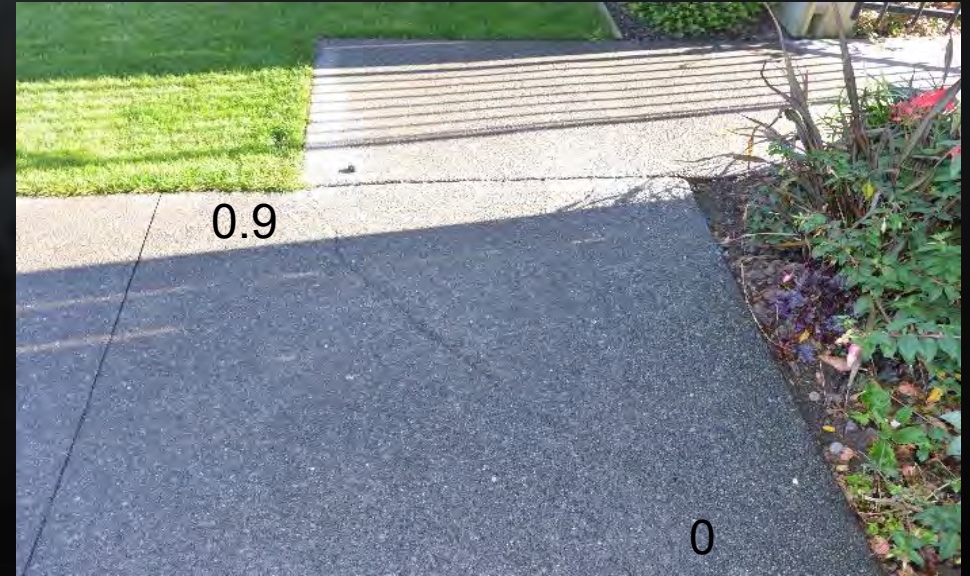

Cracking unacceptable to owner

Aesthetically Acceptable Crack Width

Stated Crack Width Limits

- ➔ CIA Z7/06 (2017) – 0.3 mm
- ➔ Eurocode EN 1992-1-1:2004 Clause 7.3.1 – 0.4 mm
- ➔ British Standard BS 8110: Part 2: 1985 Clause 3.2.4.1 – 0.3 mm
- ➔ ACI 224R-01 Table 4.1 – 0.41 mm

Industry Information

- ➔ All concrete shrinks and cracking should be expected
- ➔ Illinois Readymixed Concrete – 3mm
- ➔ National Association of Home Builders (NAHB) – 6 mm
- ➔ Rule of thumb – credit card width – approx. 0.75 mm

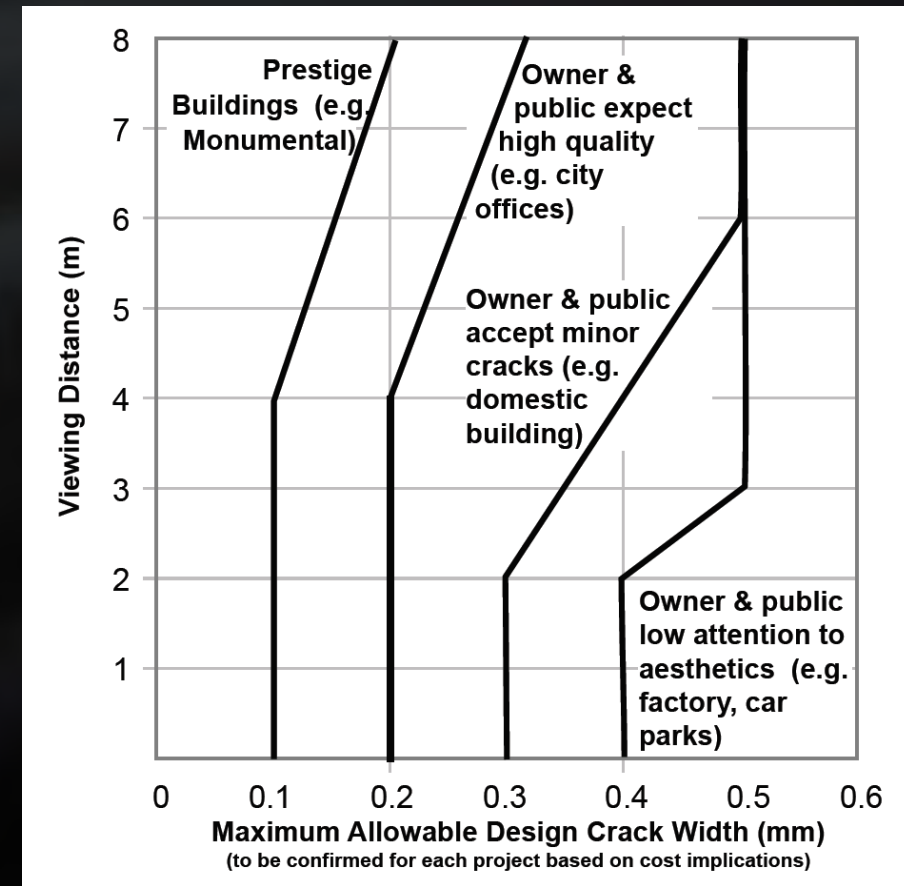

Figure 3.8 of CIA Z7/06

Problems due to Poor Construction Practices

Common Issues

- ➔ Mesh not close to surface
- ➔ Inadequate lap of mesh
- ➔ Inadequate jointing
- ➔ Poorly aligned dowels
- ➔ Reinforcement through joint
- ➔ No trimmer bars
- ➔ Inadequate isolation

Reason

- ➔ Lack of training
- ➔ Competitive market
- ➔ Subsequent contractors arrive late (sawcutting and curing/sealing)



How has AS 3727.1 addressed these issues?

Major Changes to Concrete Pavements

- ➔ Concrete strength – now consistent with abrasion requirements in AS 3600 (Table 4.6)
- ➔ Joint spacing – Generally reduced to decrease the risk of random cracking
Generally agreed that previous 6 m spacing too far apart
- ➔ Minimum reinforcement – Generally increased
 - According to ACI 360R-10 Guide to Slabs-on-Ground, “when tests and design calculations are not performed, the minimum 0.15% reinforcement is often specified”.
 - ACI 318M-14 Clause 24.4.3.2: for 500 MPa reinforcement, minimum reinforcement ratio for shrinkage and temperature steel = 0.0015
 - Reinforcement quantities
 - 100 mm thick: 150 mm²/m (SL72 = 179 mm²/m)
 - 150 mm thick: 225 mm²/m (SL82 = 227 mm²/m)

Changes to Table 5.2 of AS 3727.1 (2016)

Table 5.2 Concrete Base Parameters

Traffic	Minimum base thickness mm	Minimum concrete grade	Alternative 1 unreinforced		Alternative 2 reinforced		Alternative 3 reinforced	
			Maximum control joint spacing m	Minimum reinforcing mesh	Maximum control joint spacing m	Minimum reinforcing mesh	Maximum control joint spacing m	Minimum reinforcing mesh
Pedestrian only	75	N20	2.0 1.5	-	N/A	N/A	N/A	N/A
Pedestrians and light vehicles	100	N20 N25	2.0 1.5	-	3 2	F52 SL 62	6 4.5	F62 SL 72
Pedestrians and commercial vehicles	150	N25 N32	2	-	4	F72 SL 82	6 4.5	SL 82

Note: Values in red from 1993 Guide to residential pavements

Use of Reinforcement

Reinforcement required where:

- ➔ The panel is of irregular shape
- ➔ The length is greater than 1.5 x width (even if regular shape)
- ➔ Joint spacing greater than Alternative 1
- ➔ Re-entrant corners – 2 N12 x 1000 mm long min.

Lapping of mesh - minimum two transverse bars

Cover using bar chairs in accordance with AS/NZS 2425



AS 3727.1 Pavements Part 1: Residential

Most significant change - Reinforcement must **NOT** be continuous through control joints

Formed control joint – with shear key

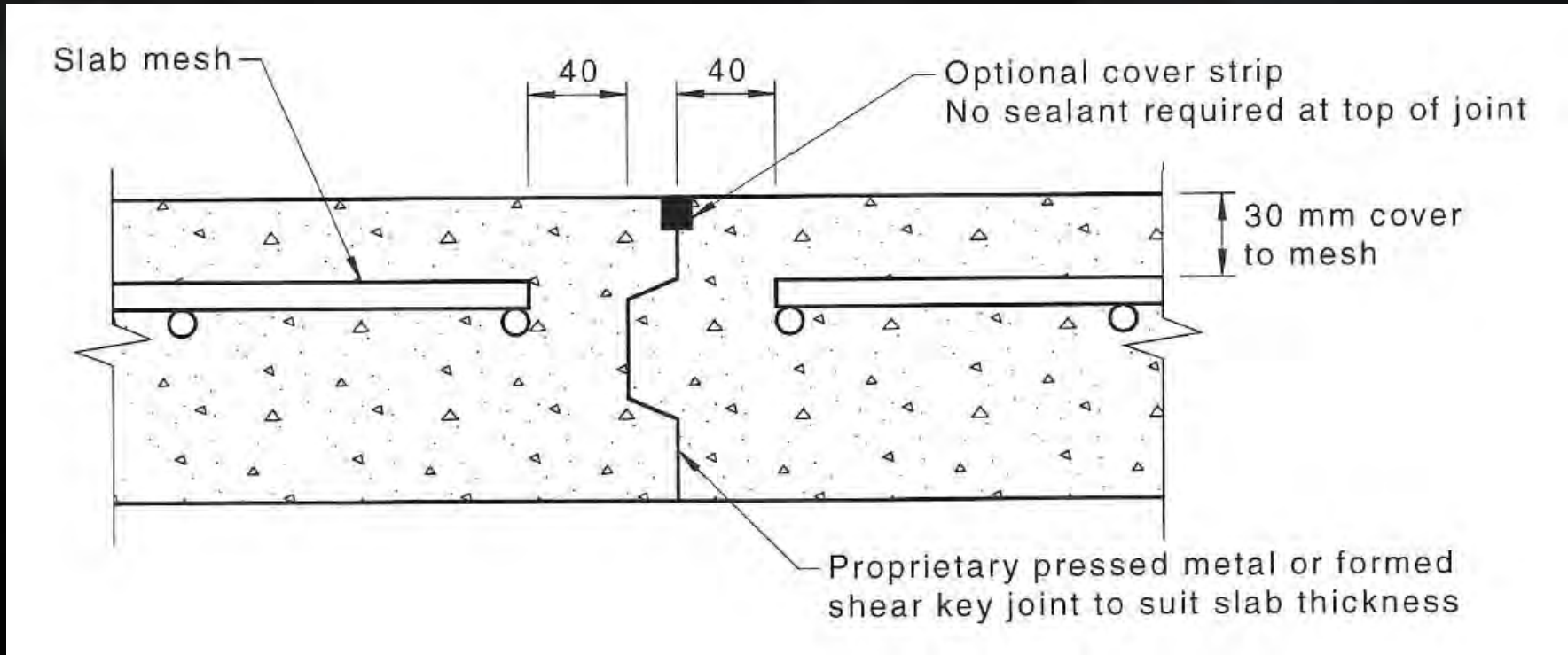

Figure 5.4.2 (a) of AS 3727.1

AS 3727.1 Pavements Part 1: Residential

Weakened plane control joint - Option of having dowel for load transfer shown

Removes reliance on aggregate interlock for load transfer

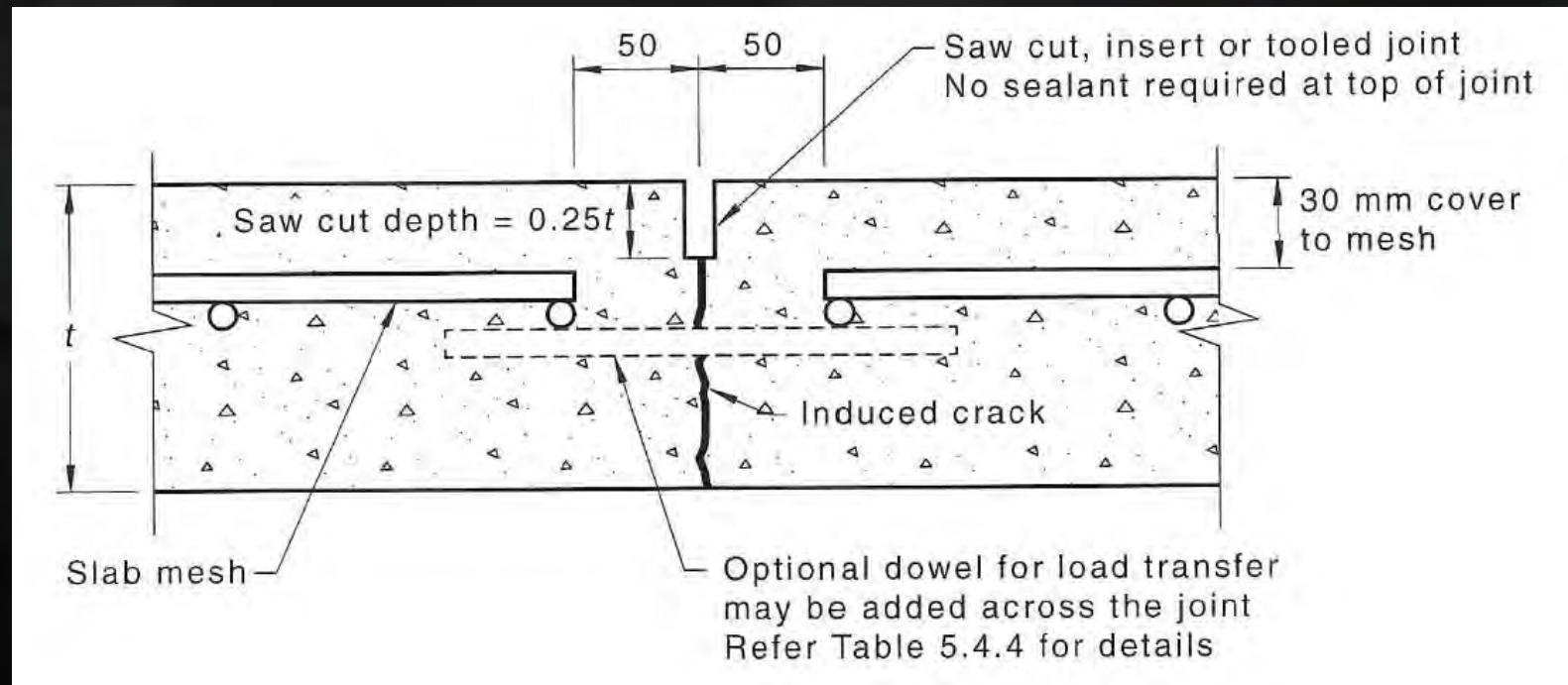

Figure 5.4.2 (b) of AS 3727.1

Create plane of weakness

- ➔ Scoring surface (tooled joint)
- ➔ Insert proprietary crack-inducing device
- ➔ Sawing the concrete

AS 3727.1 Pavements Part 1: Residential

Typical Dowelled Expansion Joint (Figure 5.4.4 in AS 3727.1)

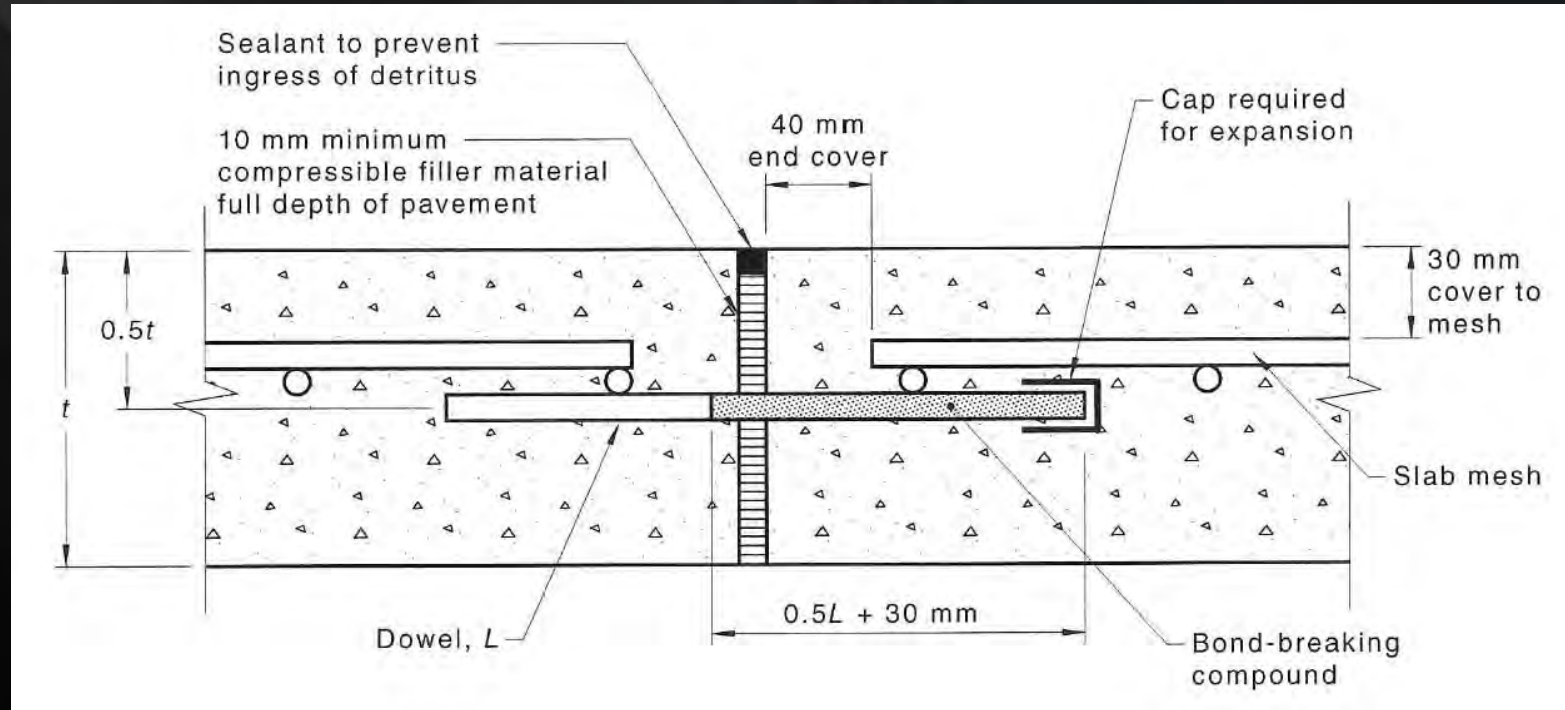

Spacing (previously no guidance)

- ➔ Plain pavements < 100 mm thick – max. 6 m centres
- ➔ Reinforced pavements \geq 100 mm thick – max, 12 m centres

AS 3727.1 Pavements Part 1: Residential

Dowel Details – Types available now that allow movement in two directions

Pavement thickness mm	Dowel Type	Dowel dimensions mm	Minimum dowel length mm	Maximum dowel spacing mm
75	N/A	N/A	-	-
100	Round	12 diameter	300	400
	Square	12 x 12	300	400
	Plate	MR	MR	450
125	Round	16 diameter	350	300
	Square	16 x 16	350	300
	Plate	MR	MR	450
150	Round	20 diameter	400	300
	Square	20 x 20	400	350
	Plate	MR	MR	450

MR – Refer Manufacturer's Recommendations

Due to variety of plate dowel types, geometries and installation methods

AS 3727.1 Pavements Part 1: Residential

Joint Requirements to reduce Random Cracking

- ➔ Continuous from edge to edge
- ➔ Sealing
 - ➔ Surfaces clean and dry
 - ➔ Concrete fully cured and reached design strength
 - ➔ Surface temperature $\geq 5^{\circ}$
 - ➔ Correct depth of sealant ($0.5W \leq \text{depth} \leq W$)
 - ➔ Sealant only adheres to sides of joint
- ➔ Saw cutting
 - ➔ Correct timing and depth
 - ➔ Clean all debris
 - ➔ No ravelling greater than 20 mm
- ➔ Dowels
 - ➔ Ensure adequate alignment and allowance for movement



AS 3727.1 Pavements Part 1: Residential

Appendix B Information on common Quality Issues

- ➔ Random crack width
 - Different to planned cracking
 - Factors causing random cracking
- ➔ Reinforcement
 - Brittle surface coverings eg tiles, decorative finishes
- ➔ Joint spacing
 - Decreased to reduce the risk of random cracking
- ➔ Joint detailing
 - Important issues concerning joint types
- ➔ Concrete
 - Importance of uncontrolled addition of water, compaction and curing

How will provisions influence random crack width?

Joint Spacing

ACI 360R-10 - 25 to 35 times slab thickness for slabs reinforced for limiting crack width

New joint spacing generally complies with these limits

Reinforcement for crack control

ACI 360R-10 recommends 0.15% for crack control

New mesh sizes generally comply with this percentage

Reinforcement through joints not allowed

No restraint to joint opening movement

Overcomes common quality issues

Guidance on quality issues (Appendix B)

Information to improve understanding and quality

Conclusions

- ➔ AS 3727.1 Pavements Part 1: Residential, now a mandatory Standard
- ➔ Industry needs to be aware of new requirements and implement
- ➔ Should have significant impact on providing crack free concrete pavements provided key quality issues are addressed
- ➔ If random cracking does occur, new provisions should control the width to an aesthetically acceptable limit (< 0.3 to 0.4 mm)

Thank you

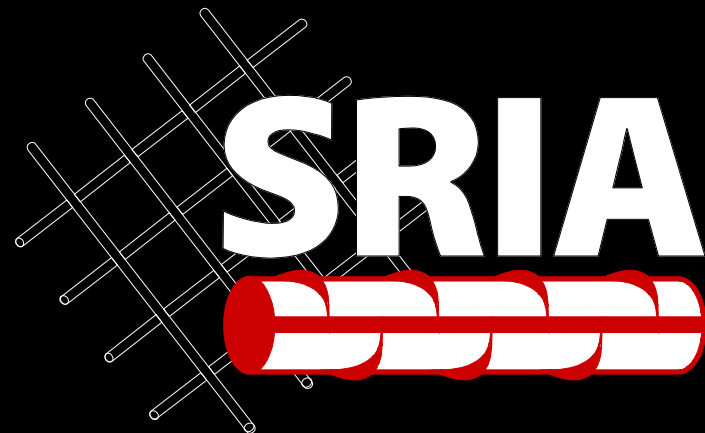

Steel Reinforcement
Institute of Australia